

FF-SR05932 Standstill and Low Speed Monitor

FEATURES

- Complies with the Machinery Directive 98/37/EC, IEC 204, EN 60204, DIN 0113 and UL 508
- Category 3 per EN 954-1
- Control reliable
- Designed for Category 1 Emergency Stop functions per EN 418 and NFPA79
- Inputs for two 3-wire proximity sensors (with PNP or NPN solid state output)
- Compatible with motors driven by frequency variators, soft starters etc.
- Rotation frequency threshold adjustable via DIP switches
- Positive-guided output contacts: two NO, one NC for 250 Vac
- Switching current up to 4 A
- Green LED for power status, green LED for rotation frequency on channel 1 and channel 2 below programmed detection level
- 45 mm / 1.77 in width housing
- Removable terminal blocks

TYPICAL APPLICATIONS

- Stopped motor monitor or low speed monitor for any kind of rotating devices
- Used to unlock a door guarding a rotating machine only when the hazardous movement is stopped
- Used in conjunction with emergency stop modules to activate an emergency brake when an e-stop signal is received and while motion is still present



(Pending)



FF-SR05932

The FF-SR05932 standstill / low speed monitor module measures the rotation frequency of rotating devices using two external proximity sensors.

When the rotation frequency falls below a programmable threshold level, the FF-SR05932 standstill / low speed monitor module will energise its safety relay outputs. Then, the two normally open contacts (13/14, 23/24) of the module will close and the normally closed contact 31/32 will open.

The detection threshold of the rotation frequency is programmable in four ranges using internal DIP switches. A fine adjustment selector helps to fine adjust the threshold frequency within the selected frequency range.

The FF-SR05932 standstill / low speed monitor module is designed to be connected to proximity sensors with PNP or NPN static outputs. Both proximity sensors must detect that rotation frequency is below the programmed frequency threshold, in order to energise both internal safety relays. Both internal safety relays K1 and K2 need to be energised to close the normally closed contacts (13/14, 23/24) of the module and to open the normally open contact 31/32.

The sensors are powered by the module. Two sensors must be connected to the module in order to have redundant inputs.

WARNING

MISUSE OF DOCUMENTATION

- The information presented in this product sheet (or catalogue) is for reference only. DO NOT USE this document as system installation information.
- Complete installation, operation and maintenance information is provided in the instructions supplied with each product.

Failure to comply with these instructions could result in death or serious injury.

FF-SR05932 Standstill and Low Speed Monitor

SPECIFICATIONS

- Safety low speed monitor for rotating devices



Supply voltage	Nominal voltage	24 Vdc/ac (ac:-20 %, +10 %; dc:-10 %, +10 %), 120 Vac (-20 %, +10 %), 230 Vac (-20 %, +10 %)	
	Nominal power consumption	ac: approx. 4 VA; dc: approx. 4 W	
	Nominal frequency	50 Hz to 60 Hz	
Proximity sensors (see Note 1)	Nominal voltage	24 Vdc (provided by the module)	
	Sensor type	3-wire type, PNP 0 V NPN solid state output	
	Current consumption	max. 20 mA per sensor	
	Switching frequency	max. 20 kHz per sensor	
	Pulse duration	min. 2 ms	
	Simultaneity condition (between two proximity sensor outputs)	max. 0,5 s (falling edge)	
	Selectable detection frequency	0,12 Hz - 312,5 Hz (DIP switch selectable in four ranges)	
Relay outputs	Response time tv	Detection frequency fd	tv=1/ fd
	Examples:	0,25 Hz	4 s
		0,5 Hz	2 s
		1 Hz	1 s
		2 Hz	0,5 s
		40 Hz	0,25 s
	Relay type	Safety relay with positive-guided contacts	
	Contact complement	2 NO contacts, 1 NC contact	
	Current range (min. to max.)	1 mA to 4 A (see Caution)	
	Voltage range (min. to max.)	0,1 to 250 Vac/dc	
	Switching capability per AC15 (EN 60947-5-1)	3 A / 250 V for NO contact • 2 A / 250 V for NC contact	
	Typical electrical life expectancy	Power factor = 1 at 230 Vac (see Note 2)	
	1 A	2 000 000 operations	
	2 A	1 000 000 operations	
	4 A	300 000 operations	
	Typical power factor (cos φ)	Limitation factor (see Note 3)	
	0,3	0,45	
	0,5	0,70	
	0,7	0,85	
	1	1	
	Fuse rating	4 A time delayed	
	Mechanical life	50 000 000 switching operations	
General	Temperature range	-25 °C to 60 °C / -13 °F to 140 °F	
	Sealing	Housing: IP 40 • Terminals: IP 20	
	Housing material	Thermoplastic	
	Vibration resistance	Amplitude 0,35 mm; Frequency 10 to 55 Hz	
	Connector connection (max.)	2 x 2,5 mm ² solid wire [14 AWG]	
	Connector attachment	1 x 2,5 mm ² [14 AWG] / 2 x 1,5 mm ² [16 AWG] stranded wire with sleeve DIN 46288	
	Mounting	Removable block terminals with M3,5 screws; wire contacts are enclosed to prevent electrical shock	
	Weight	Quick install rail mounting EN 50022-35, width: 35 mm x 15 mm / 1.38 in x 0.59 in size 410 g / 0.9 lb	

ORDERING INFORMATION

FF-SR05932 □ - □

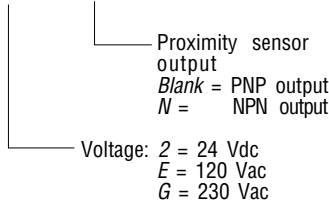

Note 1: Ensure the selected proximity sensors comply with the specified proximity sensor features.

Note 2: Install arc suppressors across load to avoid module contact arcing and ensure specified relay life expectancy.

Note 3: Total operations = operations at power factor 1 multiplied by the limitation factor. If the power factor is 0,5 at 230 Vac, 2 A (1 000 000 operations), the limitation factor is 0,70.

Total operations: 1 000 000 x 0,70 = 700 000.

CONTACT LIFE FOR 100 % RESISTIVE LOAD (TYPICAL)

Power factor = 1 (cos φ) (see Note 2)

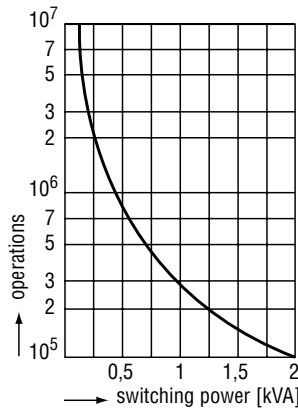

LIMITATION FACTOR FOR INDUCTIVE LOADS

Power factor < 1 (cos φ) (see Note 3)

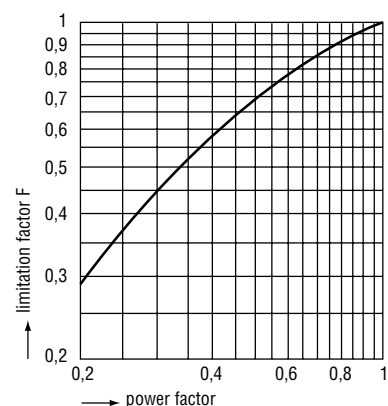

INSTALLATION DIAGRAM

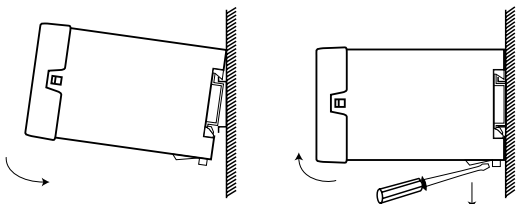

SETTING OF DETECTION FREQUENCY

Two DIP switches are used to select one of the four different ranges for the detection frequency. The fine tuning can be done using the fine adjustment selector. The DIP switches and the fine selectors are located behind the front panel.

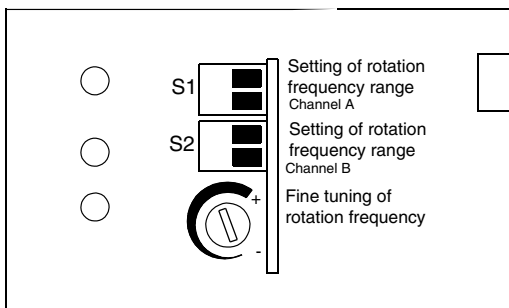

Range Hz	0.12-1.2	1.0-9.7	7.8-78	31-312
S1				
S2				

FRONT PANEL REMOVAL

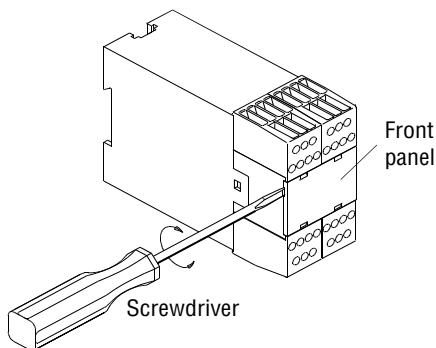

APPLICATION EXAMPLES

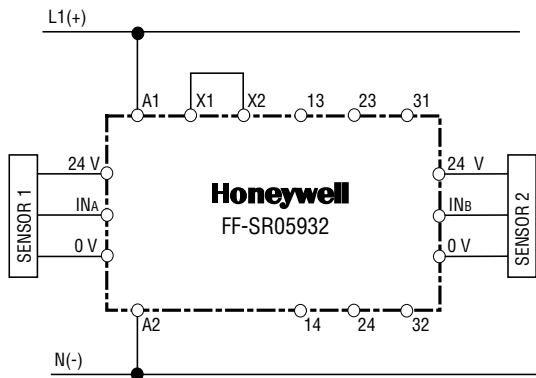

MOUNTING DIMENSIONS

Width: 45 mm / 1.8 in; Height: 85 mm / 3.3 in; Depth: 118 mm / 4.6 in

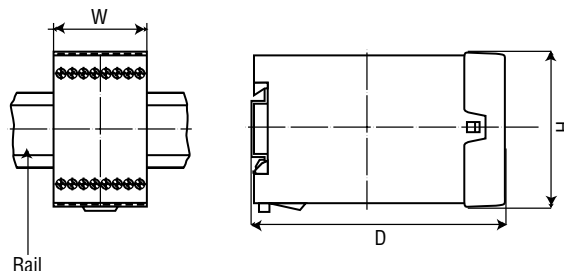

FUNCTIONAL DIAGRAM

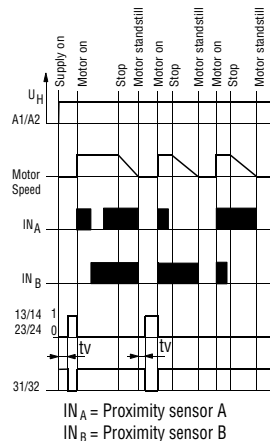

WIRING DIAGRAM

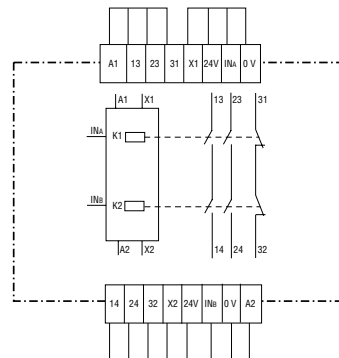

APPLICATION EXAMPLES (with external contactors)

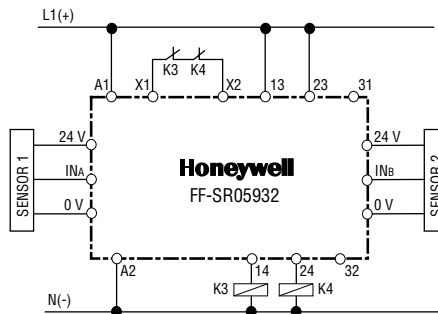

External contactors: When switching currents are higher than 4 A, the output contacts should be reinforced by external contactors with positive guided contacts (K3 and K4). The proper operation of the external contactors must be monitored by looping their normally closed contacts into the FSD-loop between terminals Y1/Y2 (FSD = Final Switching Device monitoring). If K3 or K4 is welded, the FSD loop will not close, preventing further operation of the module.

FF-SR05932

APPLICATION EXAMPLE

Door protection using a solenoid key operated safety interlock switch (GKR/GKL Series) and a standstill / low speed monitor module FF-SR05932

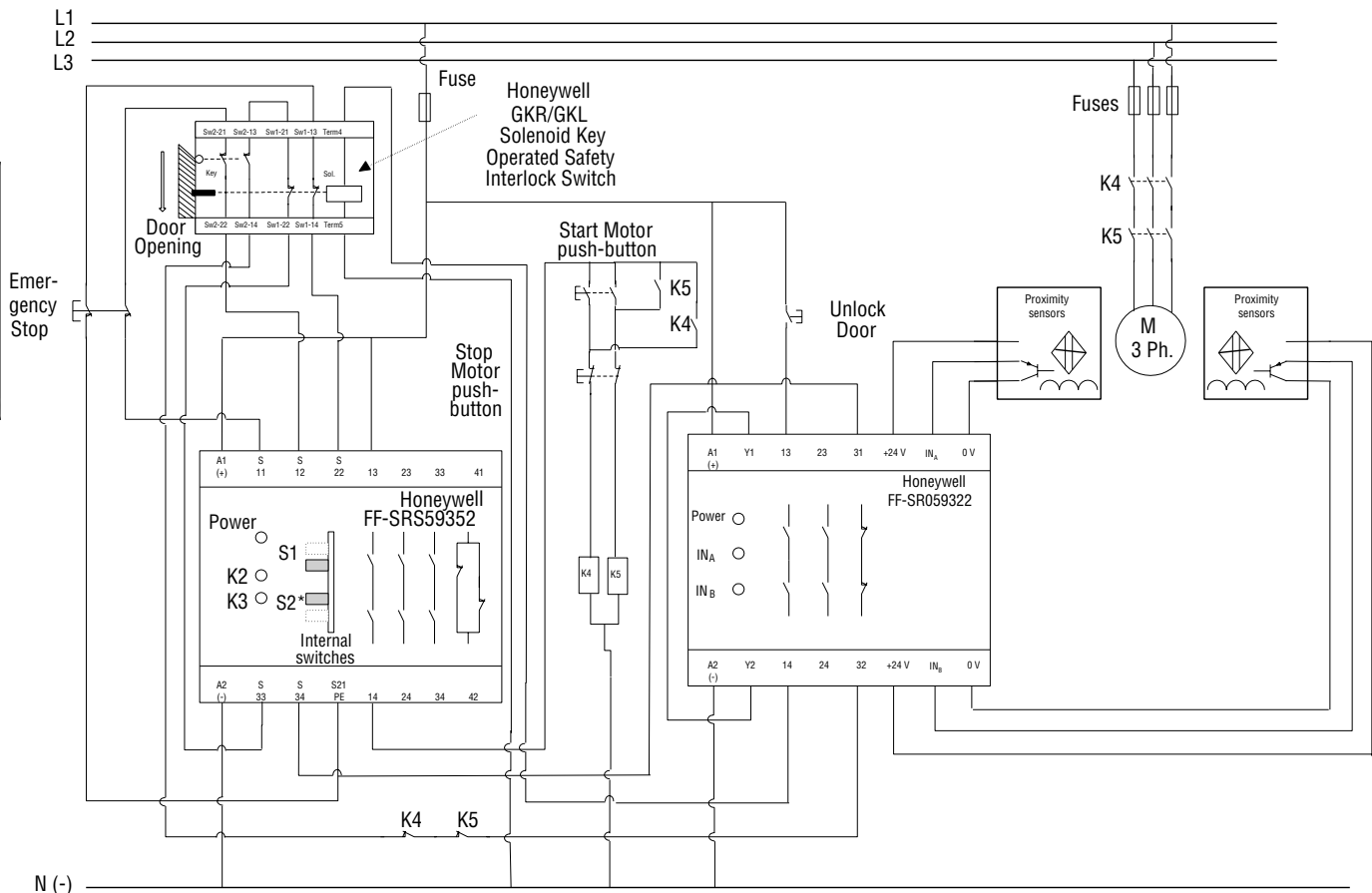

FUNCTIONAL DESCRIPTION

Start sequence

Initially, the motor is not operating and the door is open. To initiate the start sequence, close the door. This action will close the two normally closed contacts of the key operated interlock switch. It will also automatically restart the FF-SRS5935 emergency stop module. As the Unlock push-button is not actuated, the solenoid coil of the key operated interlock switch is de-energized and the door is locked.

The motor may now be started. To start the motor, press the Start Motor push-button. This action will energize the self-maintained external relays K4 and K5, and will start the motor.

Stop Sequence

Initially, the motor is operating and the door is closed and locked. To initiate the stop sequence, press the Stop push-button. This action will de-energize the external safety relays K4 and K5 and stop the motor. When the FF-SR05932 standstill / speed monitor detects the rotation frequency is below the programmed threshold level, it is possible to unlock the door. The threshold levels can be programmed by internal DIP switches and a selector for fine tuning.

In order to unlock the door, press the Unlock push-button. This action will energize the coil of the solenoid of the GKL/GKR key operated interlock switch and unlock the door. The door may now be opened. No hazardous motor motion is present anymore.

Emergency Stop Sequence

In case of an emergency stop situation, the two channel inputs of the FF-SRS5935 emergency stop control module will open. This action de-energizes the external safety relays K4 and K5, stopping the motor. All other steps remain the same as described above (Stop Sequence).

APPLICATION NOTE:

Proximity sensors with the following specifications are compatible with the FF-SR05932 standstill / low speed monitor module:

- 3-wire 24 Vdc
- PNP solid state output (for FF-SR05932□ version)
- NPN solid state output (for FF-SR05932□-N version)
- Current consumption < 20 mA.
- Maximum switching frequency: 20 kHz
- Minimum pulse duration: 2 ms

Warranty and remedy

Honeywell warrants goods of its manufacture as being free of defective materials and faulty workmanship. Contact your local sales office for warranty information. If warranted goods are returned to Honeywell during the period of coverage, Honeywell will repair or replace without charge those items it finds defective. The foregoing is Buyer's sole remedy and is **in lieu of all other warranties, expressed or implied, including those of merchantability and fitness for a particular purpose.**

While we provide application assistance, personally, through our literature and the Honeywell web site, it is up to the customer to determine

the suitability of the product in the application.

Specifications may change at any time without notice. The information we supply is believed to be accurate and reliable as of this printing. However, we assume no responsibility for its use.

Sales and Service

Honeywell serves its customers through a worldwide network of sales offices and distributors. For application assistance, current specifications, pricing or name of the nearest Authorised Distributor, contact a nearby sales office or:

INTERNET: www.honeywell.com/sensing

E-mail: info.sc@honeywell.com

ASIA PACIFIC

Sensing & Control Asia Pacific Headquarters

Phone: +(65) 355-2828
Fax: +(65) 445-3033

Australia

Honeywell Limited
Phone: +(61) 2-9370-4500
FAX: +(61) 2-9370-4525
Toll Free 1300-36-39-36
Toll Free Fax 1300-36-04-70

China - PRC - Beijing

Honeywell (Tianjin) Ltd.
Phone: +(86-10) 6561-0208
FAX: +(86-10) 6561-0618

China - PRC - Shanghai

Honeywell China Inc.
Phone: +(86-21) 6354-9181
FAX: +(86-21) 6354-2248

China - Hong Kong SAR

Honeywell Ltd.
Phone: +(852) 2331 9133
FAX: +(852) 2331 9998

China - PRC - Chengdu

Honeywell China Ltd
Phone: +(86-28) 6786-348
FAX: +(86-28) 6787-061

China - PRC - Guangzhou

Honeywell China Inc.
Phone: +(86-20) 3879-1169
FAX: +(86-20) 3879-1269

China - PRC - Shenzhen

Honeywell China Inc.
Phone: +(86) 755-518-1226
FAX: +(86) 755-518-1221

India

Tata Honeywell Ltd
Phone: +(91) 20 6875-532/534
FAX: +(91) 20 6875 992

Indonesia

Honeywell Indonesia Pte Ltd
Phone: +(6221) 521-3330
FAX: +(6221) 521-3735

Japan

Yamatate Corporation
Phone: +(81) 3 5440 1395
FAX: +(81) 3 5440 1314

South Korea

Honeywell Korea Co. Ltd
Phone: +(822) 799-6114
FAX: +(822) 792-9011

Malaysia

Honeywell Engineering Sdn Bhd
Phone: +(60-3) 7958-4988
FAX: +(60-3) 7958-8922

New Zealand

Honeywell Pty Limited
Phone: +(64-9) 623-5050
FAX: +(64-9) 623-5060
Toll Free (0800) 202-088

Philippines

Honeywell Systems (Philippines) Inc.
Phone: +(63-2) 636-1649
FAX: +(63-2) 636-1650

Singapore

Honeywell Southeast Asia
Phone: +(65) 355-2828
FAX: +(65) 445-3033

Taiwan R.O.C.

Honeywell Taiwan Ltd.
Phone: +(886-2) 2245-1000
FAX: +(886-2) 2245 3242

Thailand

Honeywell Systems Ltd.
Phone: +(662) 693 3099
FAX: +(662) 693 3085

NORTH AMERICA

Canada

Honeywell LTD
Phone: 1-800-737-3360
FAX: 1-800-565-4130

USA

Sensing and Control,
International Headquarters
Phone: 1-800-537-6945
1-815-235-6847
FAX: 1-815-235-6545
E-mail: info.sc@honeywell.com

EUROPE

Austria

Honeywell Austria GmbH
Phone: +(43) 1 727 80 366/246
FAX: +(43) 1 727 80 337

Belgium

Honeywell SA/NV
Phone: +(32) 2 728 2522
FAX: +(32) 2 728 2502

Bulgaria

Honeywell EOOD
Phone: +(359) 2 79 40 27
FAX: +(359) 2 79 40 90

Czech Republic

Honeywell spol. s.r.o.
Phone: +(420) 2 6112 3469/3424
FAX: +(420) 2 6112 3461

Denmark

Honeywell A/S
Phone: +(45) 39 55 55 55
FAX: +(45) 39 55 55 58

Finland

Honeywell OY
Phone: +(358) 9 3480101
FAX: +(358) 9 34801375

France

Honeywell SA
Phone: +(33) 1 60 19 82 68
FAX: +(33) 1 60 19 81 73

Germany

Honeywell AG
Phone: +(49) 69 8064 444
FAX: +(49) 69 8064 442

Hungary

Honeywell Kft.
Phone: +(36 1) 451 4300
FAX: +(36 1) 451 4343

Italy

Honeywell S.p.A.
Phone: +(39) 02 92146 450/456
FAX: +(39) 02 92146 490

The Netherlands

Honeywell B.V.
Phone: +(31) 20 565 69 11
FAX: +(31) 20 565 66 00

Norway

Honeywell A/S
Phone: +(47) 66 76 20 00
FAX: +(47) 66 76 20 90

Poland

Honeywell Sp. zo.o
Phone: +(48) 22 606 0900
FAX: +(48) 22 606 0901

Portugal

Honeywell Portugal Lda
Phone: +(351 21) 424 50 00
FAX: +(351 21) 424 50 99

Romania

Honeywell Bucharest
Phone: +(40) 1 2110076
FAX: +(40) 1 2103375

Commonwealth of Independent States (CIS)

ZAO Honeywell
Phone: +(7 095) 796 98 36
FAX: +(7 095) 796 98 93

Slovak Republic

Honeywell s.r.o.
Phone: +(421 7) 58247403/400
FAX: +(421 7) 58247 415

South Africa (Republic of)

Honeywell Southern Africa
Honeywell S.A. Pty. Ltd
Phone: +(27) 11 805 1211
FAX: +(27) 11 805 1354

Spain

Honeywell S.A.
Phone: +(34) 91 313 6100
FAX: +(34) 91 313 6129

Sweden

Honeywell AB
Phone: +(46) 8 775 55 00
FAX: +(46) 8 775 56 00

Switzerland

Honeywell AG
Phone: +(41) 1 855 24 40
FAX: +(41) 1 855 24 45

Turkey

Honeywell Turkey A.S.
Phone: +(90) 216 464 4764
FAX: +(90) 216 464 4794

United Kingdom

Honeywell Control Systems Ltd
Phone: +(44) 1698 481 481
FAX: +(44) 1698 481 276

Mediterranean & African Distributors

Honeywell SpA
Phone: +(39) 2 921 46 232
FAX: +(39) 2 921 46 233

Middle East Headquarters

Honeywell Middle East Ltd.
Phone: +(9712) 443 2119
FAX: +(9712) 443 2536

LATIN AMERICA

Argentina

Honeywell S.A.I.C.
Phone: +(54-11) 4383-3637
FAX: +(54-11) 4325-6470

Brazil

Honeywell do Brasil & Cia
Phone: +(55-11) 7266 1900
FAX: +(55-11) 7266 1905

Chile

Honeywell Chile, S.A.
Phone: +(56-2) 233-0688
FAX: +(56-2) 231-6679

Columbia

Honeywell Columbia, S.A.
Phone: +(57-1) 623-3239/3051
FAX: +(57-1) 623-3395

Ecuador

Honeywell S.A.
Phone: +(593-2) 981-560/1
FAX: +(593-2) 981-562

Mexico

Honeywell S.A. de C.V.
Phone: +(52) 55 5259-1966
FAX: +(52) 55 5570-2985

Peru

Honeywell Peru
Phone: +(511) 445-2136-1891
FAX: +(511) 348-3552

Puerto Rico

Honeywell Inc.
Phone: +(809) 792-7075
FAX: +(809) 792-0053

Trinidad

Honeywell Inc.
Phone: +(868) 624-3964
FAX: +(868) 624-3969

Venezuela

Honeywell CA
Phone: +(58-2) 238-0211
FAX: +(58-2) 238-3391

This publication does not constitute a contract between Honeywell and its customers. The contents may be changed at any time without notice. It is the customer's responsibility to ensure safe installation and operation of the products. Detailed mounting drawings of all products illustrated are available on request.

© 2001 Honeywell International Inc. All rights reserved.

Honeywell

Honeywell

21 Chemin du Vieux Chêne
38240 Meylan Cedex

France

Honeywell

11 West Spring Street
Freeport, Illinois 61032

USA